

REV	DESCRIPTION OF REVISION	E.C.N.	BY	APPROVED	DATE
-----	-------------------------	--------	----	----------	------

6AH IS	0.003
5AH IS	0.005
DASH	"A" DIM

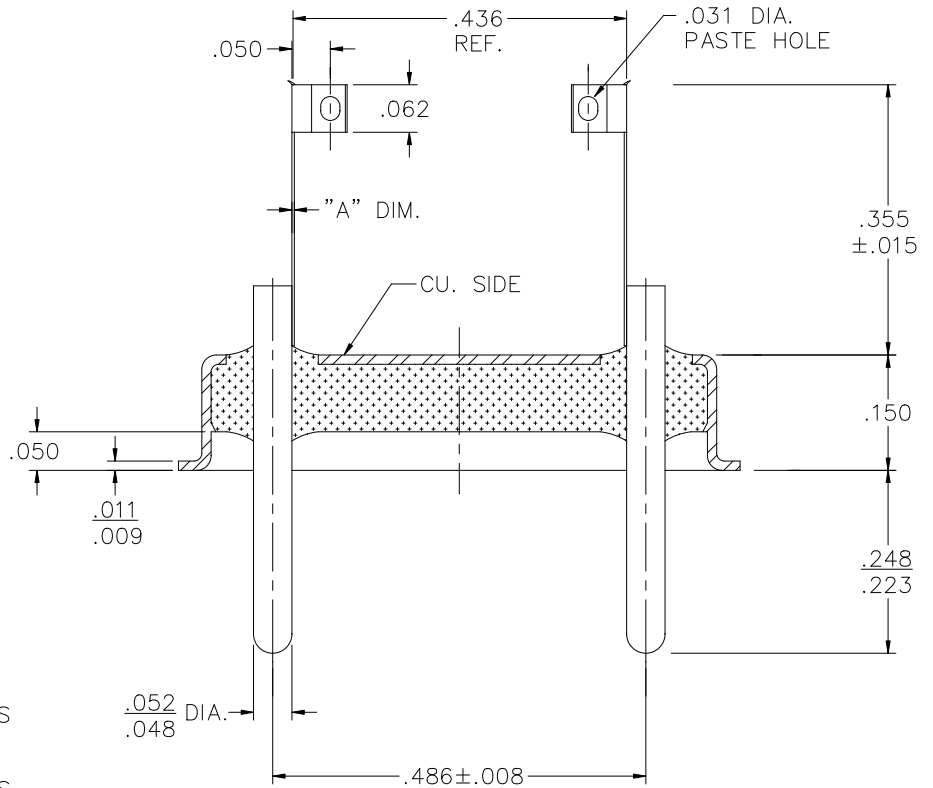
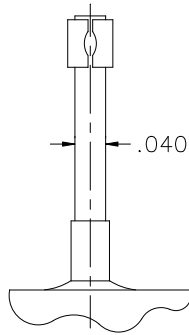
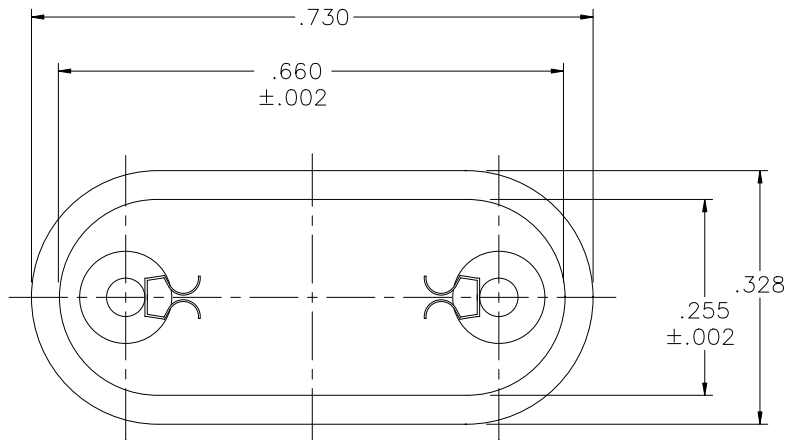

MATERIAL:

EYELET- 30/70 COPPER CLAD KOVAR.
 GLASS - 7052 OR EQUAL.
 LEADS - ASTM F-15 ALLOY, KOVAR.
 CLIPS - 301 STAINLESS STEEL.

PLATING:

1. OPTION: RoHS COMPLIANT ELECTROLESS NICKEL PLATE OF 100 MICROINCHES MINIMUM FINAL PLATE.
2. OPTION: RoHS COMPLIANT ELECTROLESS NICKEL PLATE OF 100 MICROINCHES MINIMUM FOLLOWED BY A RoHS COMPLIANT LEAD FREE SOLDER COAT, ON LEADS ONLY.
3. OPTION: RoHS COMPLIANT ELECTROLESS NICKEL PLATE OF 100 MICROINCHES MINIMUM FOLLOWED BY A GOLD FLASH OF .99999 PURE 24 KARAT GOLD UP TO A MAX. OF 8 MICROINCHES.

DRAWN BY: E.T.W. 03-24-10	MATERIAL: SEE ABOVE			TOLERANCING PER ANSI Y14.5 .X ±.005 .XXX ±.005 .XX ±.005 ANG ±5° UNLESS OTHERWISE SPECIFIED		 Legacy Technologies Inc. 6700 W. 47th TERR. MISSION, KS. 66203 TEL: 913-432-2487 FAX: 913-432-0570	
CHECKED BY:	APP. SPECS	SUPERSEDES	NEXT ASSY	SCALE: 4:1	FINISH: UNLESS OTHERWISE SPECIFIED		PART NUMBER:
APPROVED BY:	TITLE: HC-36/U W/ INSIDE TAB CLIP				CW-105-B- RoHS		
					FILE: JB00017A	PAGE	1 OF 1